

Research Proposal

For COMET (E21) Calorimeter Prototype Beam Test

COMET collaboration

Contact person: Satoshi MIHARA (IPNS, KEK)
satoshi.mihara@kek.jp

COMET Ecal Group Member list

L. Epshteyn, D. Grigoriev, N. Kuzumenko, Yu. Yudin

Budker Institute of Nuclear Physics (BINP), Novosibirsk, Russia

Y. Fukao, Y. Igarashi, T. Mibe, S. Mihara^{*}, H. Nishiguchi, N. Saito,
K. Ueno, K. Yoshimura

*High Energy Accelerator Research Organization (KEK), Tsukuba,
Japan*

P. Evtoukhovich, V. Kalinnikov, A. Moiseenko, , Z. Tsmalaidze, E.
Velicheva, A. Volkov

Joint Institute for Nuclear Research (JINR), Dubna, Russia

M. Aoki, Y. Kuno, Y. Matsumoto, A. Sato, N.D. Thong, N.M.
Truong

Osaka University, Osaka, Japan

K. Kawagoe, K. Ooishi, J. Tojo, T. Yoshioka

Kyushu University, Fukuoka, Japan

^{*} Contact person for the beam test

Abstract

We request beam time to conduct a COMET calorimeter beam test at K1.1BR line in J-PARC. The calorimeter is one of indispensable detector components to identify the electron signal of the mu-e conversion ($\mu+A \rightarrow e+A$) and to carry out beam background study in COMET Phase I. The signal electron has an energy of 105 MeV for the case of COMET where aluminum is used as a muon stopping target. The calorimeter design needs to be optimized to achieve the best performance in this energy region with reasonable position and time resolutions. We plan to evaluate the calorimeter performance using the beam test results and reflect them to advance the calorimeter design.

COMET Calorimeter

The COMET calorimeter is used to identify the signal electron by measuring its energy, position, and arrival time in combination with track information. The calorimeter is also used for beam background study in COMET Phase I. The signal electron of the mu-e conversion process has an energy of 105MeV, which is low enough to be affected easily by multiple scattering. Due to this, COMET detector components are located in vacuum inside a solenoid magnet and thus need to be operational in vacuum. In addition reasonable pile-up rejection capability is required for calorimetry.

Non-organic scintillator is a suitable material for this purpose. Readout sensors of the scintillation light have to be tolerable against magnetic field as large as 1-2 Tesla although this can be easily realized using semiconductor devices. The decay time of the scintillation light is necessary to be less than a few hundred nano seconds to identify pile-ups efficiently, which could potentially introduce misidentification of the signal. Table 1 summarizes various scintillating materials widely used in particle physics experiment. Considering these requirements, we have been conducting calorimeter R&D work, until now, using two types of crystals; LYSO and GSO.

Table 1 Properties of non-organic scintillator currently available

	GSO(Ce)	LYSO	PWO	CsI(Pure)
Density (g/cm ³)	6.71	7.40	8.3	4.51
Radiation length (cm)	1.38	1.14	0.89	1.86
Moliere radius (cm)	2.23	2.07	2.00	3.57
Decay constant (ns)	600, 56	40	30, 10	35, 6
Wave length (nm)	430	420	425, 420	420, 310
Refraction index	1.85	1.82	2.20	1.95
Light yield (Nal(Tl)=100)	3, 30	83	0.083, 0.29	3.6, 1.1

We consider that Avalanche Photo-diode (APD) with a dimension of the sensitive area of 5x5mm² is a compromise as a photo sensor (Hamamatsu S8664-55). The APD has sufficiently large quantum efficiency with a small readout capacitance, providing precise and stable measurement. Signals from APDs have to be amplified before processing for trigger and data acquisition. We have developed a fast low-noise electronics optimized for the APD and performed a prototype test successfully.

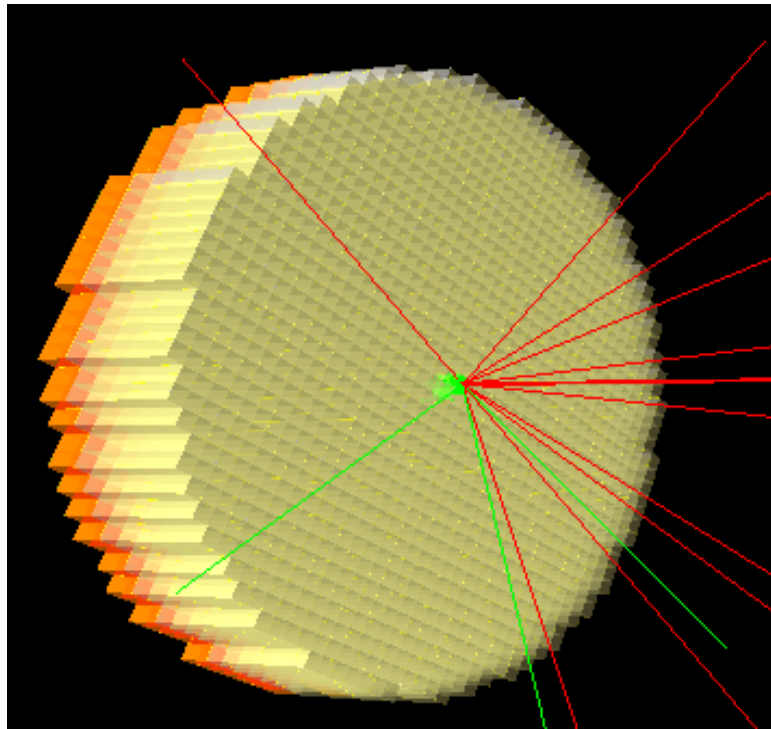

Figure 1 Schematic view of the COMET calorimeter. Simulated tracks are also shown.

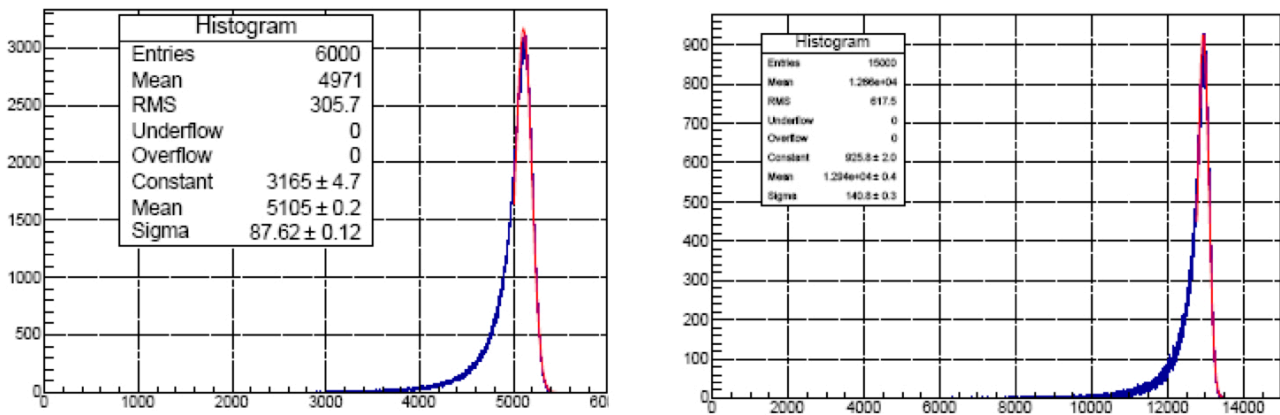

Figure 2 Reconstructed energy distributions of the COMET calorimeter simulation events. 105MeV electrons are impinged to the detector center. (left) for GSO crystal array and (right) for LYSO crystal array.

We plan to use an array composed of about 2,000 crystals of $2 \times 2 \times 15 \text{cm}^3$ in the final configuration of COMET. Figure 1 shows a schematic view of the array with simulated tracks where an electron of 105MeV impinges on the calorimeter surface. Simulation is performed assuming uniform magnetic field along the array cylinder axis of 1T. Energy responses to 105MeV electrons are shown in Figure 2 (left) for GSO crystal and (right) for LYSO crystal.

According to the simulation study we conducted taking all available information into account, LYSO shows better performance in energy measurement (1% in sigma for 105MeV electron) than GSO crystal (1.7% in sigma for 105MeV electron). This is mainly because of the scintillation photon statistics. LYSO is expected also to have better capability to identify pile-up events thanks to its faster decay time constant. However

GSO performance evaluated in the simulation is also good enough for achieving COMET phase II sensitivity. It should be noted that production cost of GSO is much lower than that of LYSO because of raw material prices. The resolutions quoted above do not include any effect such as electronics noise and gain variation of photo sensors; evaluation of these effects is also an important issue of the prototype study.

Calorimeter Prototype

In order to advance R&D work of the COMET calorimeter, we are building a prototype of the calorimeter. That is composed of 40 crystals of $2 \times 2 \times 12 \text{cm}^3$ and 9 crystals of $2 \times 2 \times 15 \text{cm}^3$ arranged in a 7×7 array. Longer crystals are located at the center of the array. We use GSO crystals as a base design because of procurement easiness. The array and its supporting structure is made in such a way that central 3×3 crystals can be easily replaced to study different type of crystals. We have at the moment 9 LYSO crystals of a dimension of $2 \times 2 \times 15 \text{cm}^3$. These will be used for performance comparison between GSO and LYSO; the central crystals give principal information of calorimetry and surrounding 40 crystals give compensating information of energy leakage from the center.

Figure 3 shows a drawing of the array holder. The array is supported from both sides. Front faces of the crystals are aligned to a flat plate, which will be removed when we test the prototype.

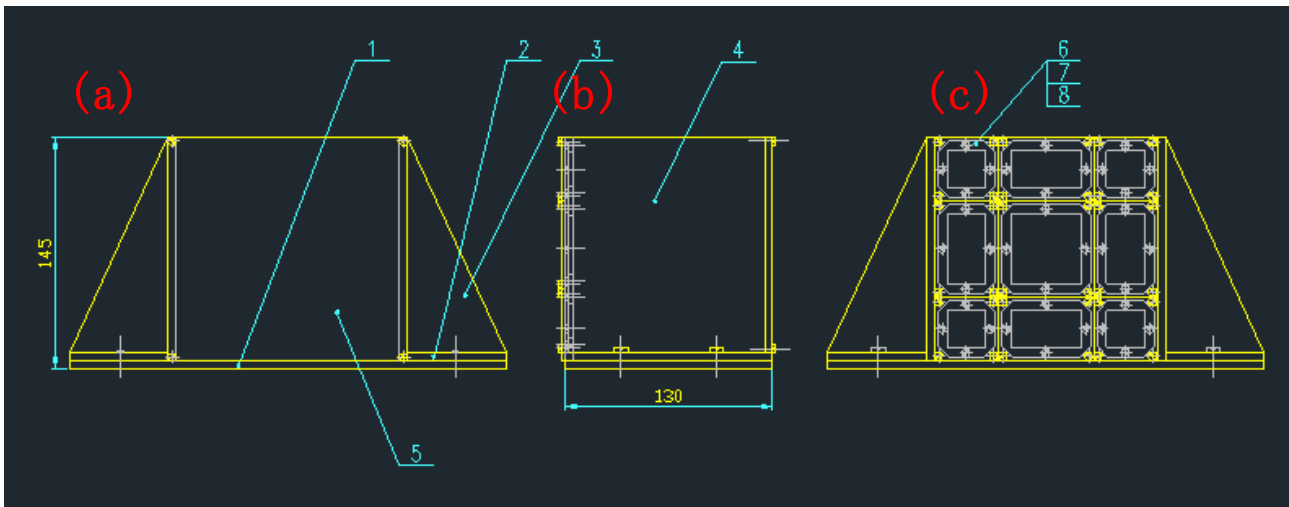

Figure 3 Drawing of the crystal array holder (a) front view, (b) side view, and (c) backside view.

In Figure 3 (c) shown are APD holders. One APD is attached to a crystal for scintillation readout. There are three kinds of APD holders for this prototype; one for 4 crystals located at the array corners, one for 9 crystals located at the center, and the other for 6 crystals at remaining locations.



Figure 4 Schematic view of crystal and APD assembly.

Figure 4 shows a schematic view of crystal and APD assembly. Each crystal is wrapped with two layers of PTFE sheet of $76\mu\text{m}$ thickness (Saint-Gobain, NORTON, shown in yellow in the figure). A base plate and crystals are wrapped with an aluminized Mylar sheet of $20\mu\text{m}$ thickness to press APDs toward crystals (shown in blue). A transparent silicon rubber of 2mm thickness (ELJEN Technology, EJ-560) is used as an optical contact between the APD and crystal.

Both of GSO and LYSO have sufficiently large light output; quantum efficiency of APD is substantially high. However due to the lower gain of APD compared to that of photomultiplier or MPPC, it is necessary to amplify the APD signal before processing. For this purpose we have developed a dedicated amplifier with fast response. The circuit diagram is presented in Figure 5.

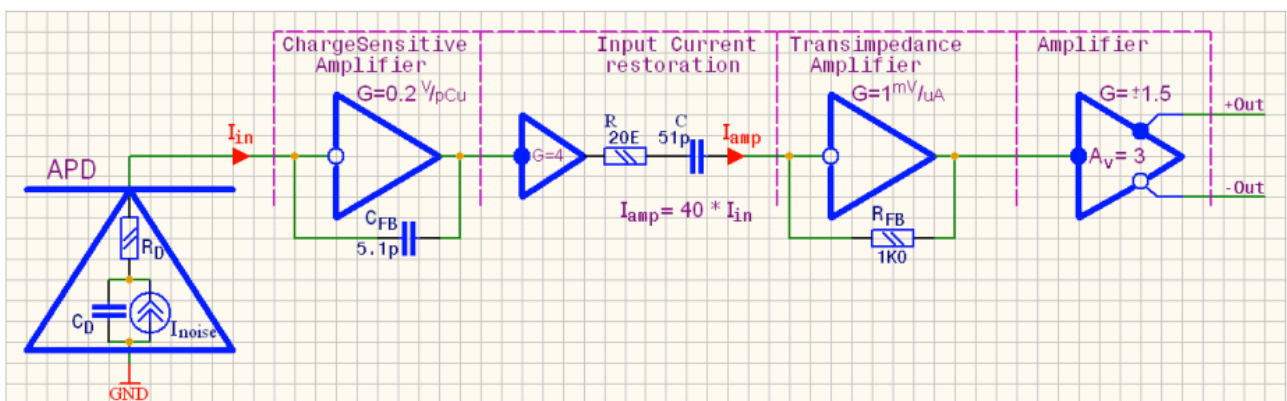

Figure 5 Preamplifier circuit diagram for the COMET calorimeter prototype

The amplifier output is designed to be differential so that the signal can be transmitted relatively long distance without being suffered from noise. The receiver circuit of the preamplifier signal is designed to convert the differential signal to single-ended and to produce trigger signal with an analog adder. The single-ended signals are passed to waveform digitizer (CAEN V1724). Figure 6 shows a schematic diagram of the whole circuit.

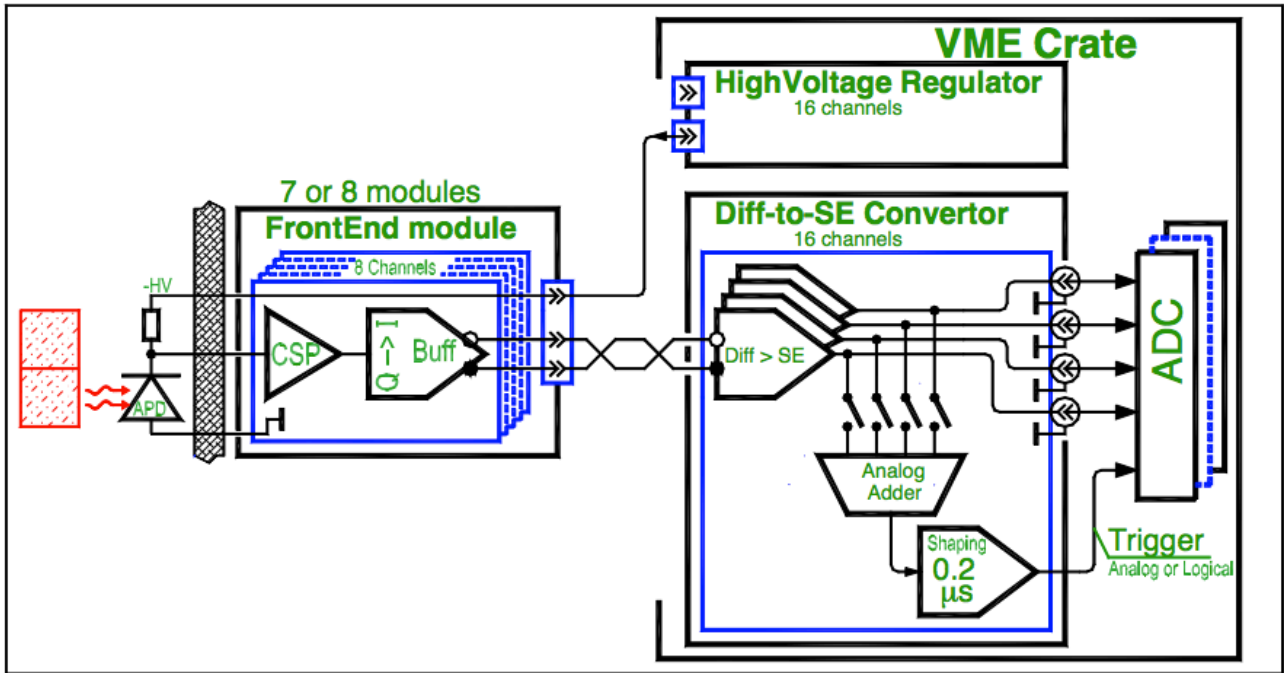

Figure 6 Schematic diagram of the COMET calorimeter prototype electronics.

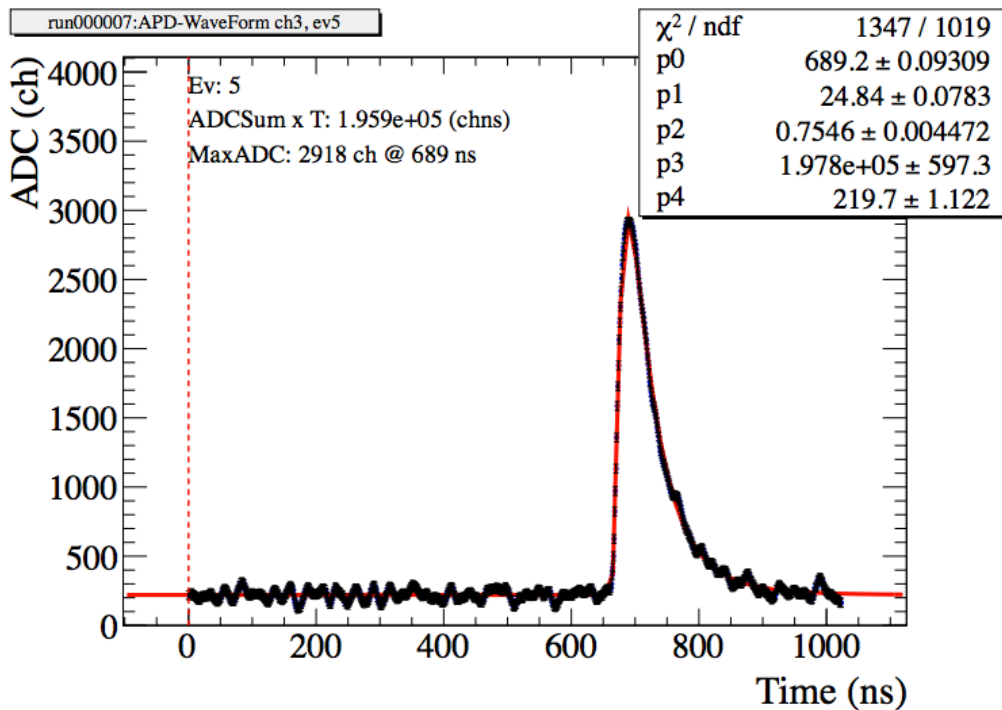

Figure 7 Example waveform taken with the COMET calorimeter prototype electronics.

Figure 7 shows a typical waveform taken with the prototype electronics. It can be seen that the noise level is suppressed sufficiently. Further noise reduction is expected by waveform analysis to evaluate the integrated charge.

K1.1BR Beam Line

We plan to conduct a beam test at K1.1BR line at J-PARC Hadron Hall. The beam line is capable to deliver secondary particles up to 1.1 GeV/c produced at a secondary target (T1 target) located on the primary beam line of the Hadron Hall. An electro-static separator is equipped in the beam line to distinguish secondary particle mass using an electro-static field in combination with magnetic field. Layout of beam line components and optics example calculated using Transport Program are shown (for 1.1GeV/c beam) in Figure 8 and in Figure 9 respectively.

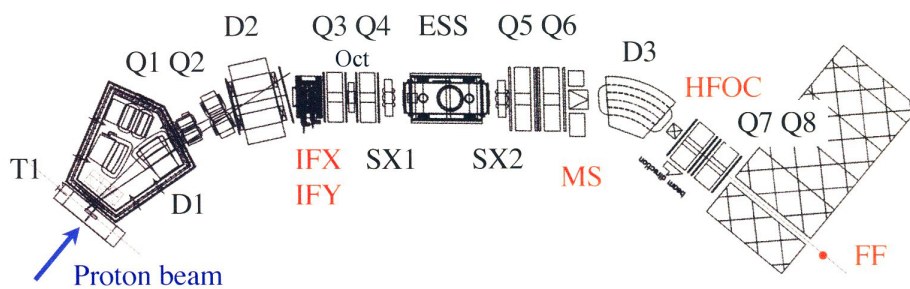

Figure 8 Layout of K1.1Br beam line

We use electron beam of about 100MeV/c for the test. D1 and D2 magnets are used to determine the secondary particle momenta. The electro-static separator is set to transmit only electrons to downstream. A slit in the horizontal direction (IFX) located after the dipole magnet (D2) is used to limit the momentum bite. HFOC is used to restrict horizontal beam spread before entering the quadrupole doublet. A preliminary measurement conducted at K1.1BR in December 2012 shows that 10-100 electrons/spill (at 11kW Main Ring operation) can be delivered to the final focusing point with a reasonable suppression of other particles. Measurement of the electron beam using a NaI detector of 5-inch diameter shows that the energy spread ranges 3.2% to 3.5% in sigma as shown in Figure 10. This is small enough to evaluate the COMET calorimeter performance. Here the number of electrons and momentum spread depends on the slit setting, which needs to be optimized further when the prototype test is conducted. Narrowing the HFOC

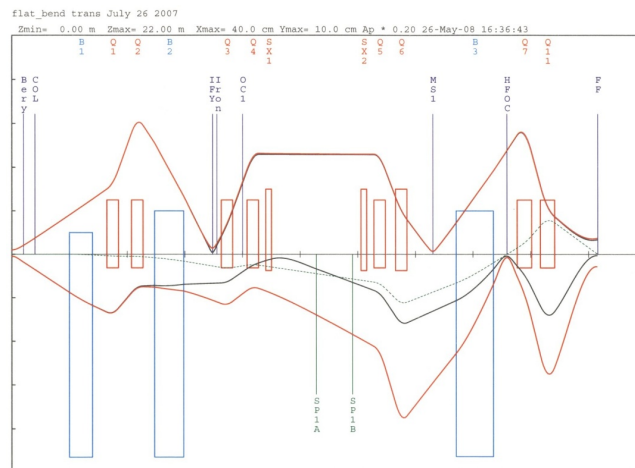

Figure 9 Beam transport optics of K1.1BR beam line

reduced low energy events in the NaI spectrum. This could be due to electrons from in-flight decay. Further reduction of low energy background could be made with the electro-magnetic separator in the K1.1BR, which we didn't have time to study in December test. Note that the measured momentum spread includes the energy resolution of the NaI detector and energy straggling effect caused by the beam line hodoscope (5mm thick plastic scintillator) equipped in the K1.1BR line.

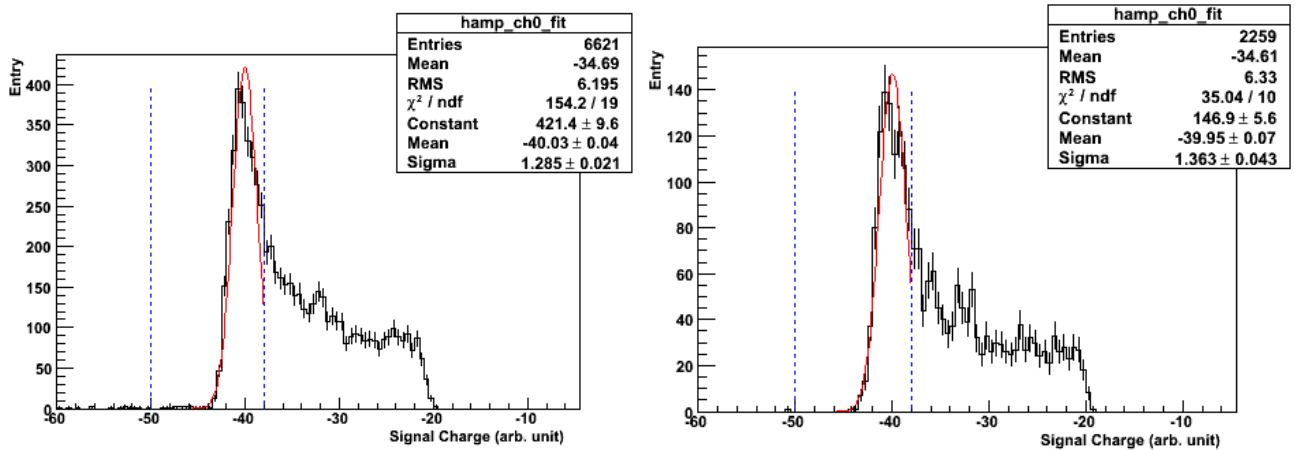

Figure 10 Charge distributions observed with a 5-inch diameter NaI detector at K1.1BR line for 100MeV/c positrons. (Left) shows a charge distribution obtained with a narrow slit setting of IFX and fully opened setting of HFOC while (right) shows with a wide slit setting of IFX and narrow slit setting of HFOC.

Setup

A schematic view of the beam test setup is shown in Figure 11. The hodoscope counter currently equipped in K1.1BR line will be replaced for this test with a thinner beam counter (1mm thick) without segmentation. A position-defining counter is located in front of the prototype. All setup are installed in a dark box with a temperature control. Dry cooled air is continuously supplied to the box from an air cooler. Temperature of individual crystal and electronics is monitored using temperature sensor (PT100) equipped on each. All setup is located on a movable stage for studying the position dependence of the performance.

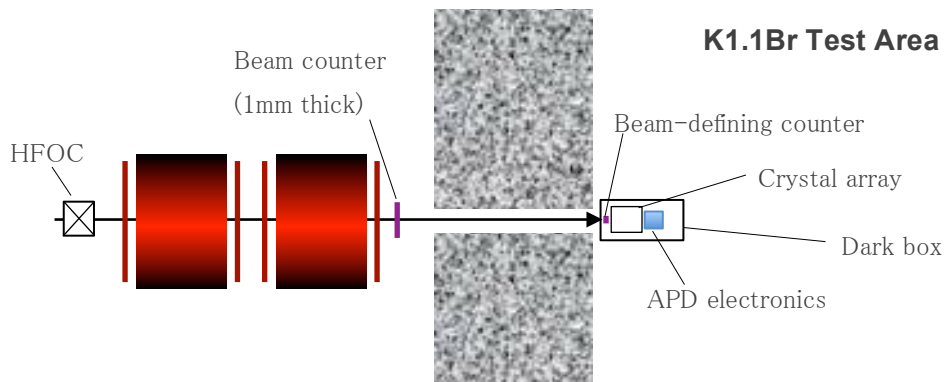

Figure 11 Setup of the COMET calorimeter beam test

All APD waveform data is recorded using waveform digitizer modules functioning in the VME crate in which signal receivers of preamplifier signal are also installed. A sampling speed of 1GS/s is used for signal recording. Online data acquisition and slow control of the experiment is achieved using MIDAS data acquisition system.

Beam time request

We request beam time of 168 hours (7 days) to conduct the test. This includes beam set up for 12 hours, position dependence study using 105MeV/c electron beam for 108 hours, and energy response study at 90MeV/c-120MeV/c for 48 hours. We need to change the D1 magnet setting for the energy response study, which will affect the beam momentum at K1.8 lines. This estimate is made based on the result of the preliminary test at K1.1BR line in December 2012. The beam electron rate is supposed to be 10 electrons/spill with 11kW Main Ring operation. Data acquisition time could be reduced when the Main Ring is operated at higher beam intensity.

Table 2 Requested beam time for the COMET calorimeter test

	Momentum	Beam time
Beam tuning	90-120 MeV/c	12 hours
Position dependence study	105 MeV/c	108 hours
Energy response study	90-120 MeV/c	48 hours
Total		168 hours

Summary

We request beam time of 168 hours at K1.1BR to evaluate the performance of the COMET calorimeter prototype. The beam momentum will be set to 105MeV/c for the position dependence study and to 90-120MeV/c for energy response study. The prototype construction is in progress to be completed in January 2013. Calibration and initial test using cosmic rays will be performed within February 2013.

Results obtained in this test are invaluable for finalizing the COMET calorimeter design. We would like to complete the test as early as possible.

Acknowledgement

We would like to thank the TREK group for their support in the preliminary test at K1.1BR in December 2012.